

## TYPE "D"

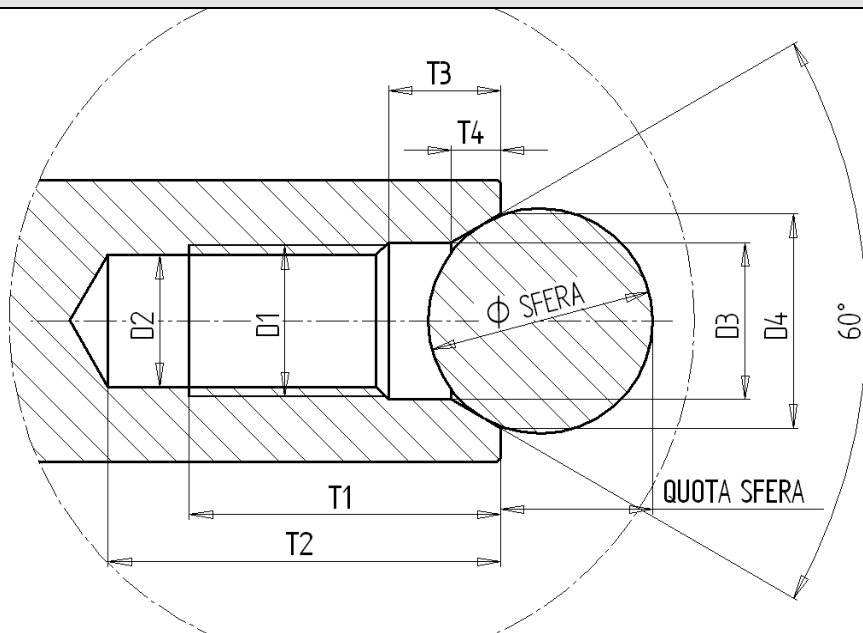

D1	D2	D3	D4	T1 <sub>+2/+0</sub>	T2 <sub>MIN</sub> (variable size)	T3	T4	Ø SPHERE	MEASURE OF CONTROL
M3	Ø 2.5	Ø 3.2	Ø 4.9	9	13	2,3	1.5	Ø 5	3.26
M4	Ø 3.3	Ø 4.3	Ø 6	10	14	2.6	1.5	Ø 6.5	4.55
M5	Ø 4.2	Ø 5.3	Ø 7.3	12.5	17	3.3	1.7	Ø 7.14	4.39
M6	Ø 5	Ø 6.4	Ø 8.5	16	21	4	1.8	Ø 9.52	6.92
M8	Ø 6.8	Ø 8.4	Ø 10.7	19	25	4.7	2	Ø 12	8.73
M10	Ø 8.5	Ø 10.5	Ø 13	22	30	5.9	2.2	Ø 14.28	10.16
M12	Ø 10.2	Ø 13	Ø 15.9	28	37.5	7.6	2.5	Ø 17	11.73
M16	Ø 14	Ø 17	Ø 20.1	36	45	9.5	2.7	Ø 22	15.59
M20	Ø 17.5	Ø 21	Ø 24.5	42	53	11.6	3	Ø 27	19.28
M24	Ø 21	Ø 25	Ø 29	50	63	13.5	3.5	Ø 32	22.89

**ES: D M8 DIN 332**

(M8= reference D1)